

Intelligent Variable-Speed High-Precision Medium-Load Pan-Tilt Head

HS-YJ020W-G

I. Pan-Tilt Head Characteristics

1. The maximum load is 25Kg;
2. The repeated positioning accuracy is $\pm 0.01^\circ$;
3. The shell is made of high-strength aluminum alloy;
4. Adopt worm gear and worm drive, which can be self-locked when power is off;
5. Horizontal continuous rotation of $0 \sim 360^\circ$;
6. Protection grade IP66;
7. Can be upgraded to network pan-tilt head;
8. Optional pan-tilt head azimuth value, camera focal length value, focus value and other information feedback functions;
9. It can be used in ships, high-speed trains, motor trains, subways and other scenes;



II. Detailed Technical Indicators:

Model	HS-YJ020W-G
Colour	Ice ash (army green, black, white, * can be customized)
Spin velocity	Horizontal $0.01^\circ \sim 12^\circ/\text{s}$ (the maximum speed can be selected in the range of 0.01° -* 30° , and the higher the speed, the smaller the load). Pitch $0.01^\circ \sim 8^\circ/\text{s}$ (the maximum speed can be selected in the range of 0.01° -* $15^\circ/\text{s}$, and the higher the speed, the smaller the load).
Angle of rotation	Horizontal continuous rotation of $0 \sim 360^\circ$ (optional limited rotation, with the maximum angle of $1^\circ \sim 320^\circ$); Pitch- $45^\circ \sim 45^\circ$ (customizable, optional in the range of 90° - 90° , the larger the angle, the smaller the load);
Presetting bit	200 Piece
Positioning accuracy	$\pm 0.01^\circ$
Repeatability	$\pm 0.01^\circ$
Self-checking	Power-on self-test (* no self-test option)
Position return	Optional (query return, real-time return)
Pilot switch	* Optional (2 groups, passive, normally open)
Lens preset position	* Optional (support, adaptive to FUJINON, COMPUTAR, KOWA and other lenses)
Lens control speed	* Optional (zoom and focus control speed can be adjusted continuously)
Automatic cruise	2, each with 40 cruise points.
Automatic homing	Automatic homing time of $1 \sim 60$ minutes can be set.
Automatic scanning	1 article
Salt spray prevention	* Optional (when the PH value is between 6.5 and 7.2, after 48 hours of continuous spraying, the machine works normally and the surface has no obvious change).
Protocol	PELCO_D ((PELCO_P, ModBus-RTU optional))
Communication baud rate	9600bps (2400/4800/115200bps optional)

Communication interface	RS485(RS422/RS232/* network interface * Wireless remote control optional)
Input power range	DC24V(*AC220V optional)
Power consumption of whole machine	≤150W
Static power consumption	≤5W
Working temperature	-25℃~+55℃,90%±3%, Noncondensation (*-40℃~+55℃ optional)
Storage temperature	-40℃~+65℃
Load(height of center of gravity 50mm directly above the top plate)	20kg(different speed, angle and gravity center height, different load)
Measure	336*190*372
Overall weight	20Kg
Bearing mode	Top load(optional side load)
Transmission mode	Worm gear and worm drive
The protection grades	IP66
Installation mode	Fixed installation(* car-mounted/* hanging load is optional, and the load capacity is halved when the car is mounted)
Remarks: * The functions marked are extra charges, please know.	

III. Dimensional Drawing

1) Pan-tilt head outline dimension drawing

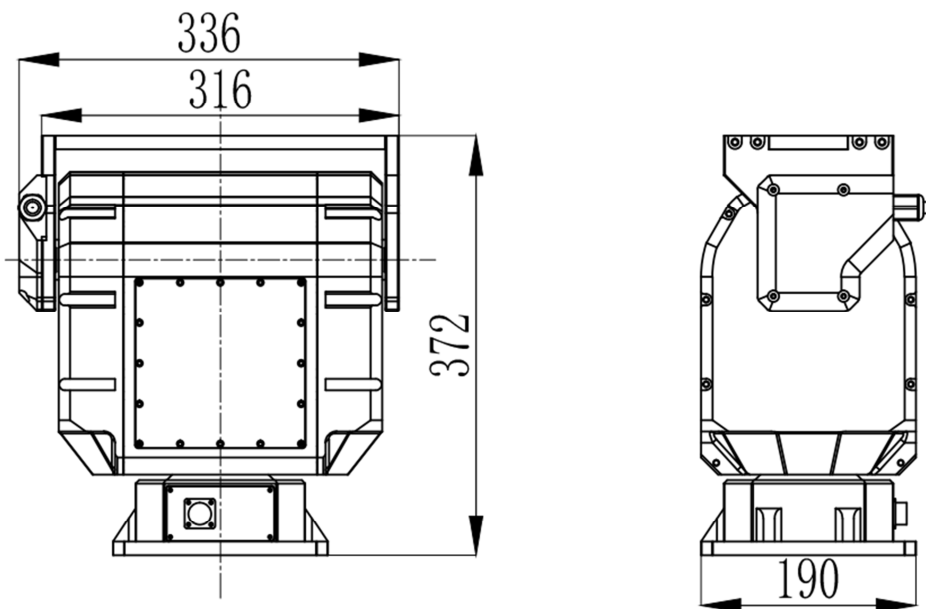

2) Pan-tilt head Roof Dimension Drawing

Top plate fixing hole (removable top plate)

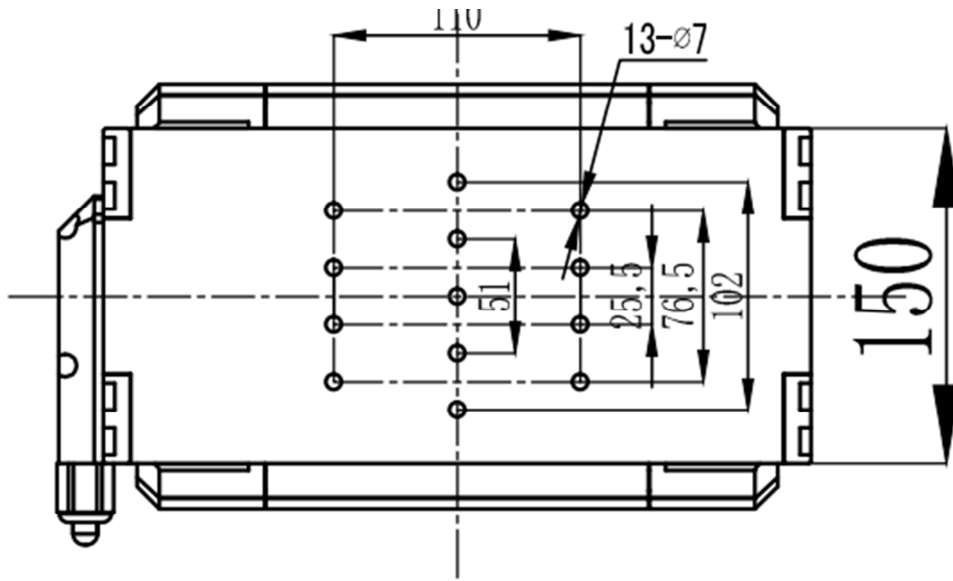

3) Installation dimension drawing of pan-tilt head base

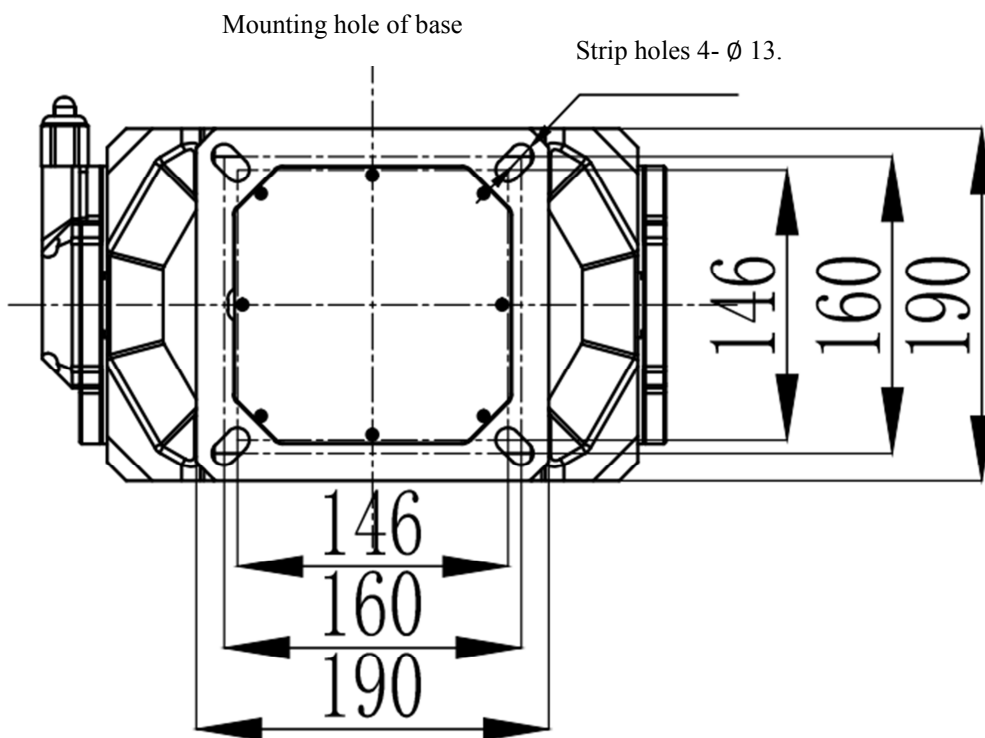

IV. Outside View Drawing

